

# X25-8.4-45

## Technical Specification

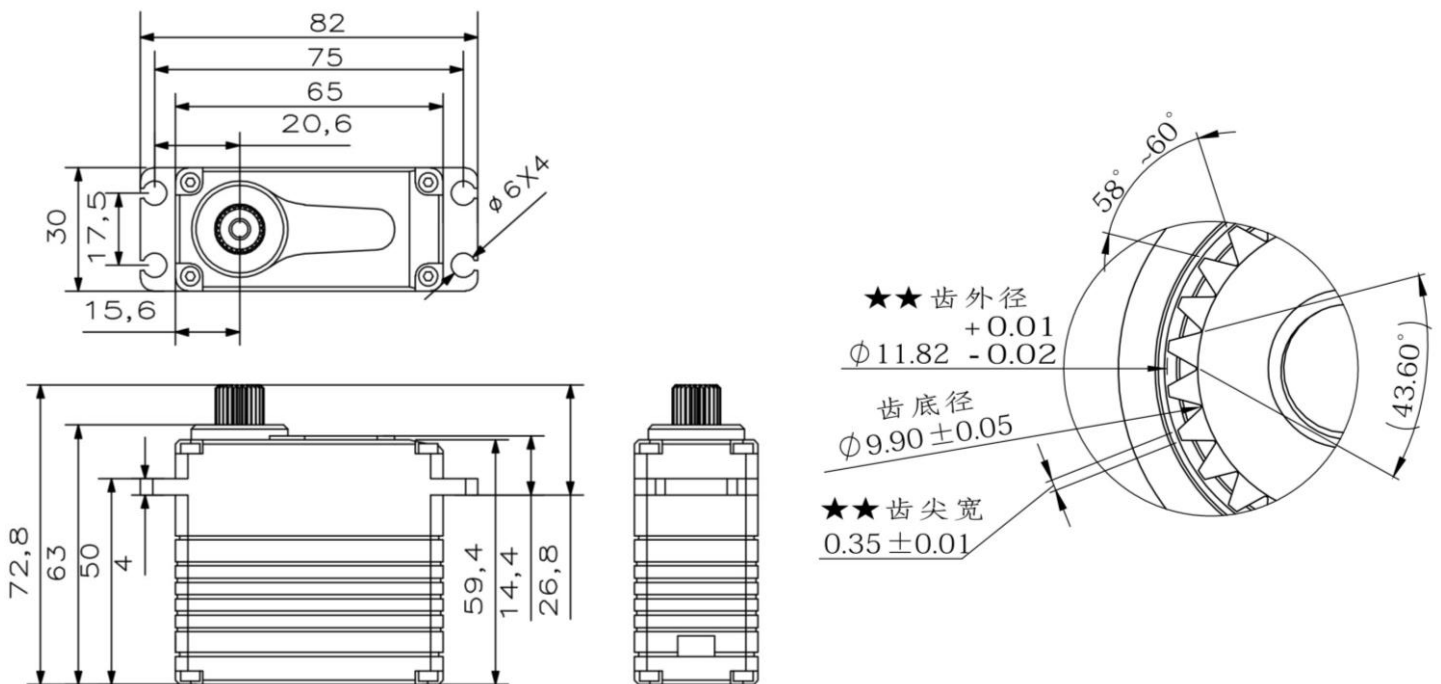



## Operating Data

	<b>X25-8.4-45</b>
<b>Operation Voltage(rated)</b>	DC7.4V
<b>Operation Voltage Range</b>	DC6.0-8.4V
<b>Torque</b>	38Kg.cm@6.0V
	42Kg.cm@7.4V
	45kg.cm@8.4V
<b>Speed</b>	0.15sec/60 °@6.0V
	0.13sec/60 °@7.4V
	0.11sec/60 °@8.4V
<b>Travel Angle</b>	±50° when 1000-2000us
<b>Operating Temperature Range</b>	-20°C .....+65°C

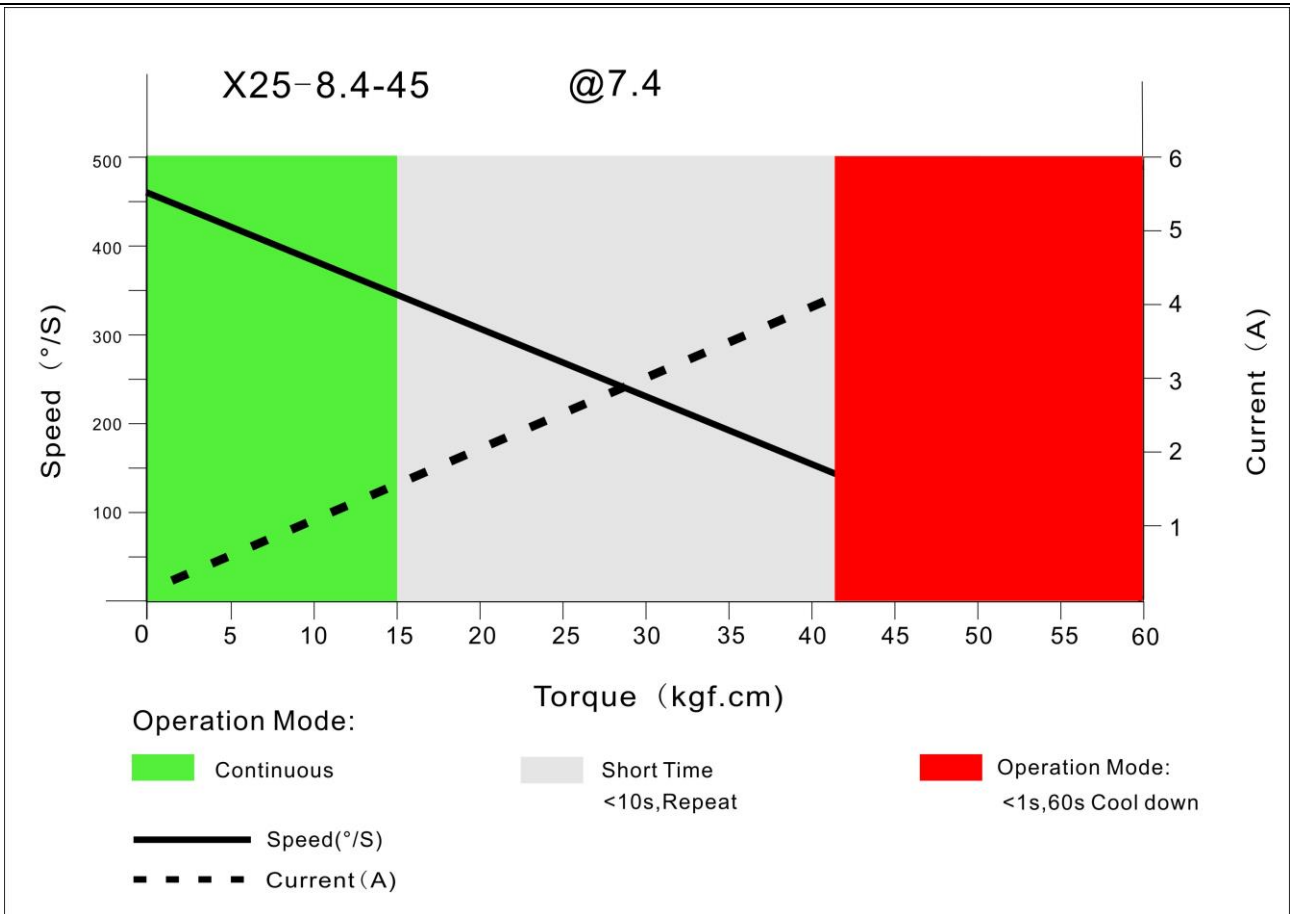

## PWM Command Signal

PWM	X25-8.4-45
Signal Voltage	TTL-Level: HIGH:min.3.3V,max.5.0V TTL-Level: Low:min.0.0V,max.0.5V
Pulse Lengths	900-2100us
Pulse Lengths for Position -50° /center/+50°	1000us/1500us/2000us
Resolution	<2us

## Materials and protective features

Case Material	Aluminum Alloy 7075
Splash Surface Treatment	
Salt Water Resistance	
EMI/RFI Shielding	
Motor Type	Coreless
Gear Set Material	Hardened Steel
Position Sensor	Potentionmeter
Position Feedback	Optional
Shielded Connecting Cable	

## Dimensions

Case Dimensions	65*30*63mm
Weight	270g

# 舵臂尺寸图

